

CABLOFIL®

INNOVATORS IN CABLE MANAGEMENT

A Group product by

 **legrand®**



...CABLOFIL, the Wire Mesh Cable Tray



II. The CABLOFIL® concept

The CABLOFIL® concept : easy, fast & complete

The unique cable tray with a high quality level

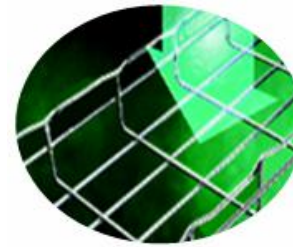
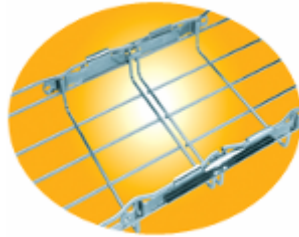

No bolts no nuts

Homologation ISO 9001



Fast Assembling

E30 – E90



Patenting Fast Assembling System

European Standard conformity



CABLOFIL® Patented

IEC 61537 – Cable Tray norm conformity



Safe-T-Edge™



CABLOFIL Wire Mesh Cable Tray



From 30 to 150 mm



From 50 to 600 mm

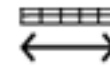

3 meters

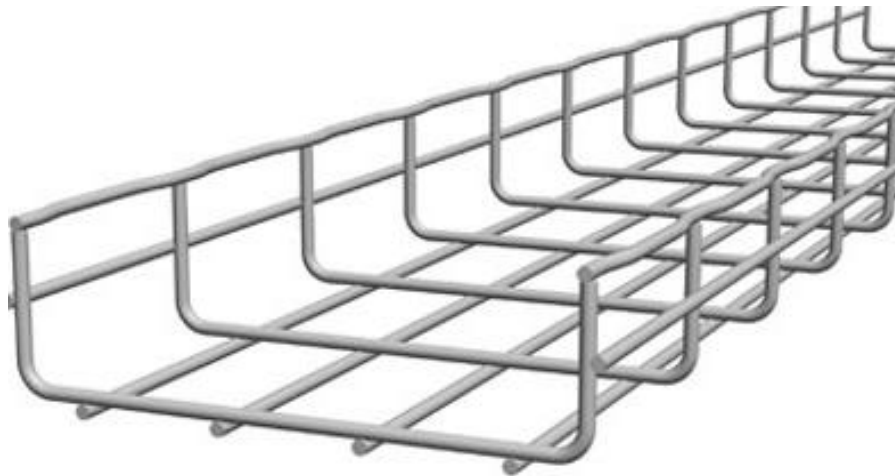

Available in:



Easy Cutting



Why CABLOFIL®

Safe T Edge - Prevent your cable from being Hurt

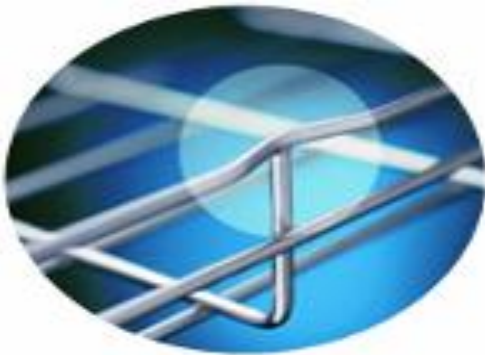

T welding the lateral wires to the top wires **eliminates the risk of damaging the cable** during installation and **protects the installer** from any sharp edges

Pull your cables from every point inside or outside the cable tray. **Side Loading Possible**

Mechanical Performance

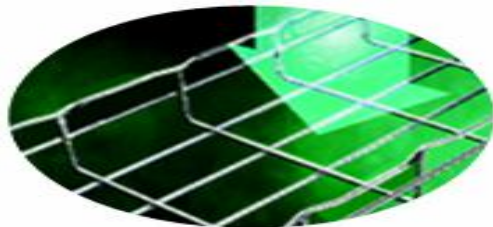

The mix of the wire diameters ensures an optimal mechanical performance to CABLOFIL trays



Its ecologically Friendly, Promoting Green Concept

Industrial Waste Reduction :30% Less steel is used compared to the traditional Trays

Safeguarding the Environment : Cablofil uses surface treatment without Chromium, the fumes are filtered and a closed water cooling loop is used. In addition 100% of Cablofil rage can be recycled

Energy Saving : Ventilation of Power cables in Cablofil improves Heat Dissipation thus reduces the losses by appx 10%.



Better visible control

trouble shooting of a system is made easy with the open design as cables can be viewed from below

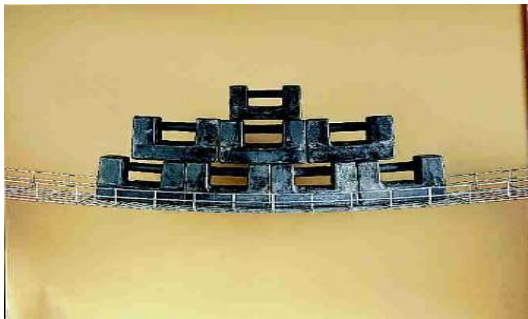

Lightweight Design- Heavy Loading Capacity
Strength & Stability – Wide Supporting Distance Possible

Tray design allows overloading without letting cables down.

A Fast & Flexible System- Drive your imagination

- ☞ CABLOFIL® requires 3 times less accessories as compared to conventional systems
- ☞ Derivations (level changes, T's, curves) are made easy by bending the cable tray

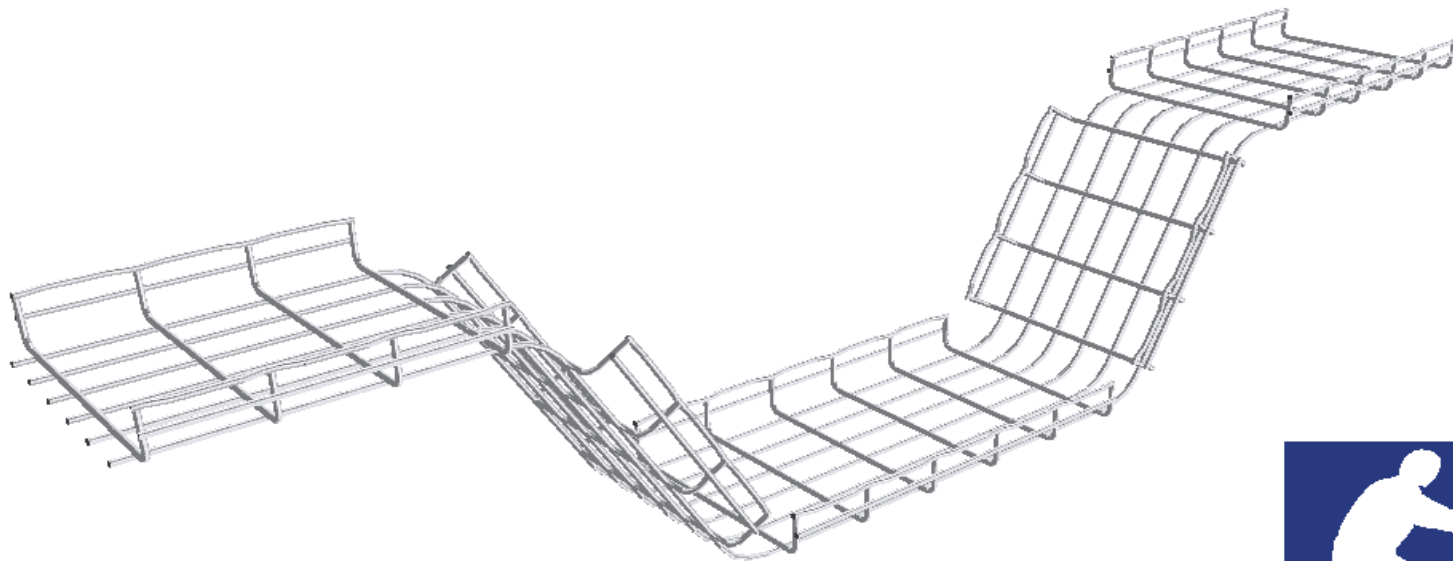

Easy to clean-no dust retention



Its simple Cut and bend it



Save time on Specification takeoffs and design, less no of acessories, just Estimate the total length needed & ... u r done



FAST & ECONOMIC



No need of specific accessories like T's, elbows, drops



Easy Logistic, reduce your surface of Storage and freight Expenses



Light weight Design - Upto50% less installation time



3 times fewer references

Imagine any complex Structure and do it with Cablofil





Complex Structure - EASY

Easy to control...

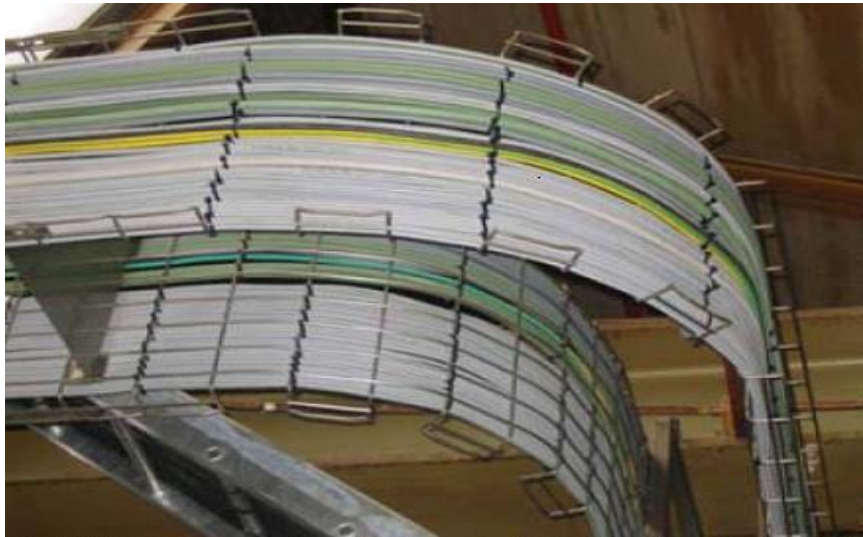

Change of levels possible

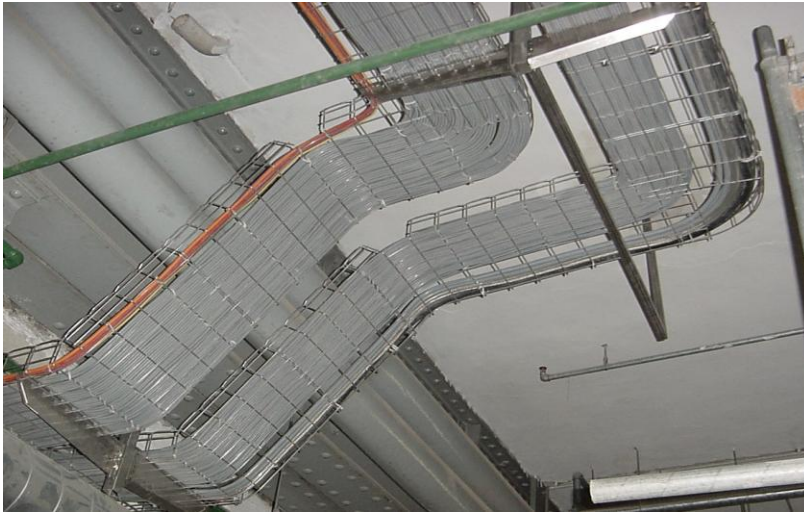

...on wall, ceiling & pendants mounting



CABLOFIL® for Power Cables

Better PERFORMANCE of Cables

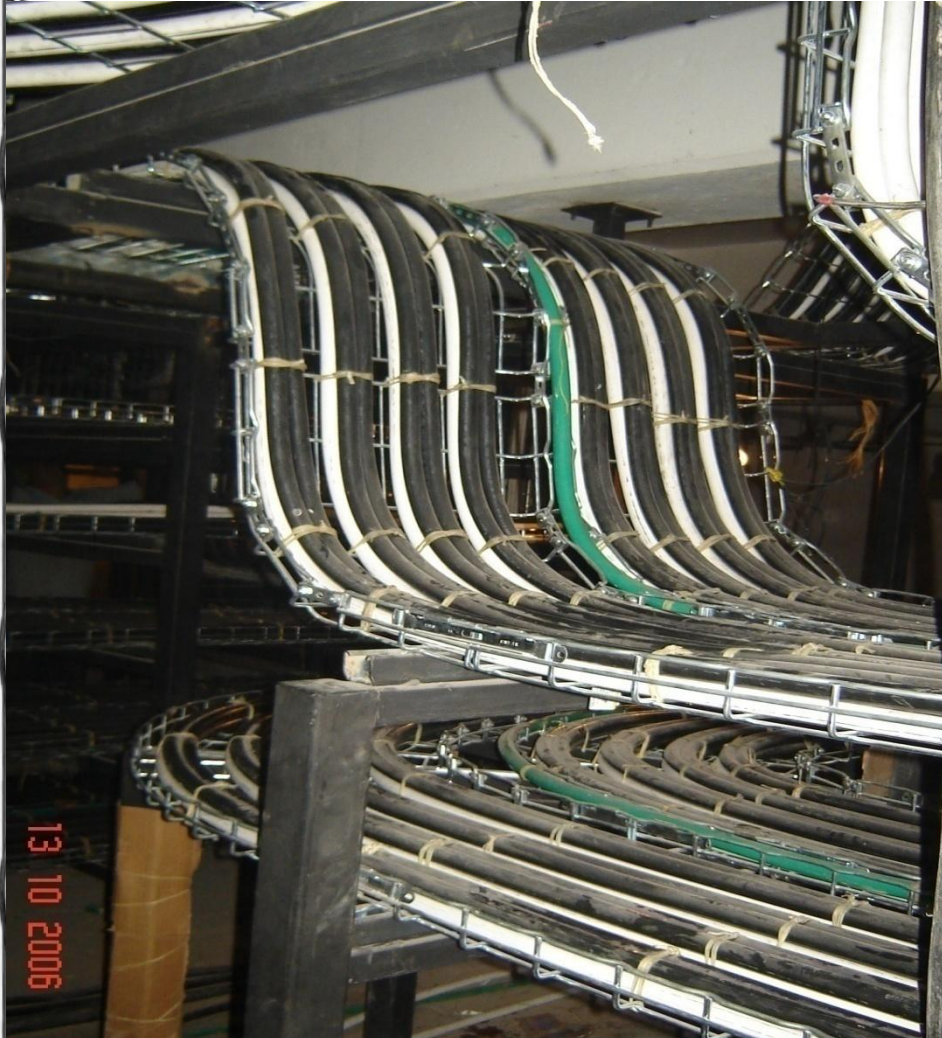
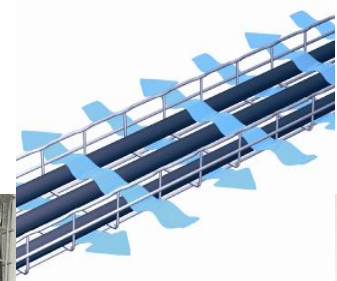

Natural Cable Ventilation / Natural Cooling



Has the same solidity but is more flexible than standard cable tray

It's a Open Structure

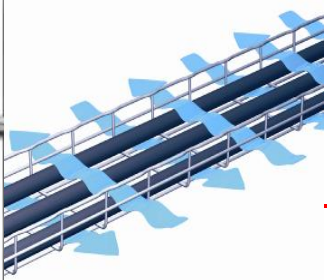

Optimization of Cable Cross Section



Reduction of Heating Effect and to prevent loss of energy.

Easy Bending

Any bends possible as per cable bending radius



bend of small radius possible : with no additional accessories



Never

Danger



But...

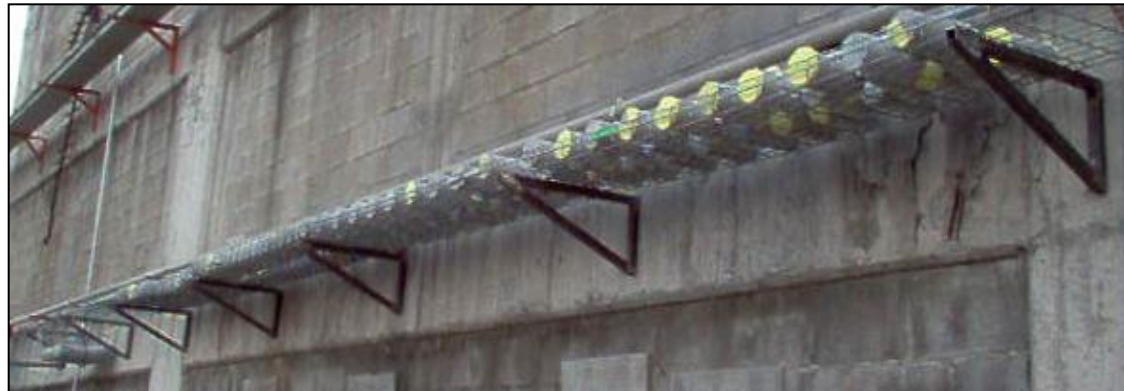
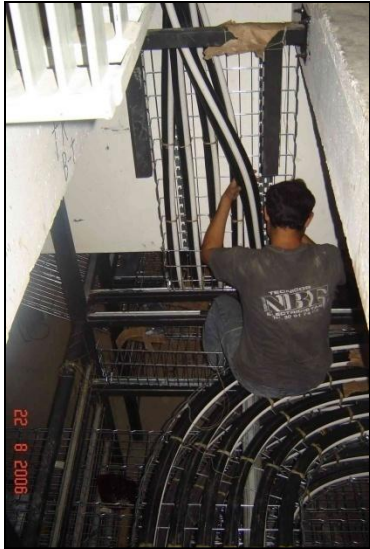

High Loading capacity

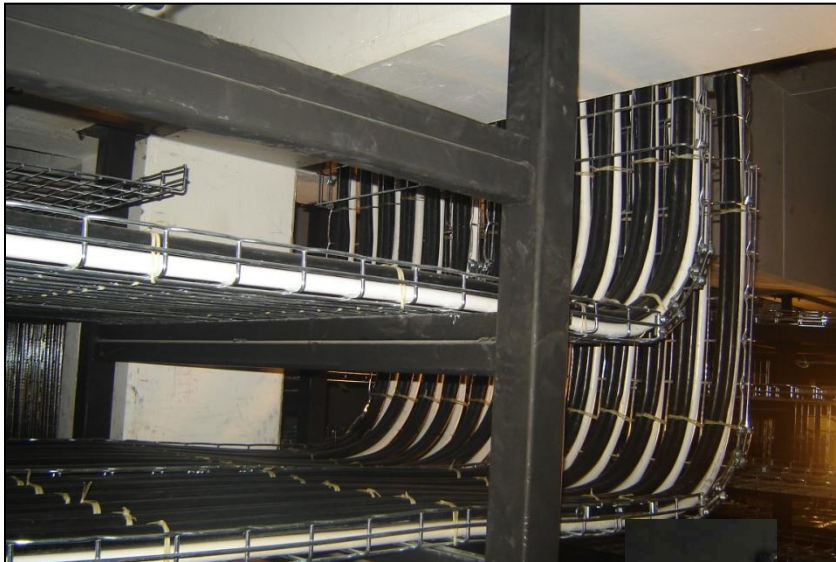
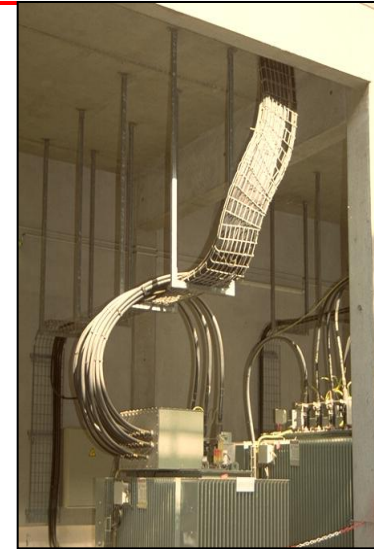
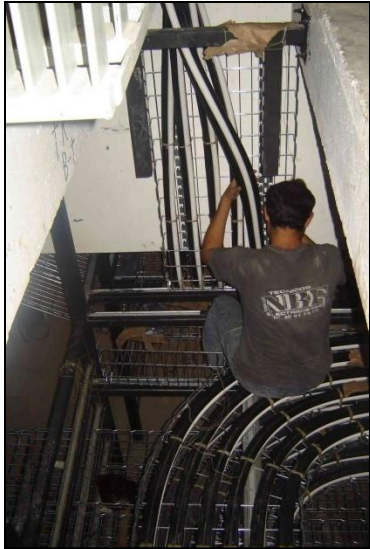

Pl attach the Movie Here, after showing Cablofil USPs
You can show them the movie

CABLOFIL® The clean solution

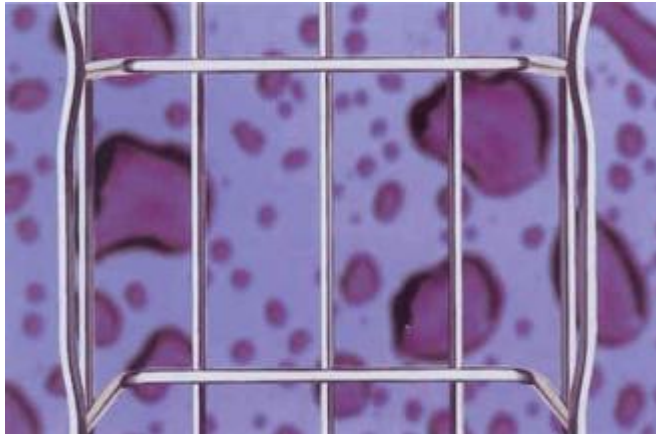

- Unique safety edge
- Open structure
- Stainless Steel 304L & 316L passivated and cleaned
- Horizontal edge mounting

- Easy to clean
- No dust retention
- No bacteria
- No risk of contamination
- Easy to control

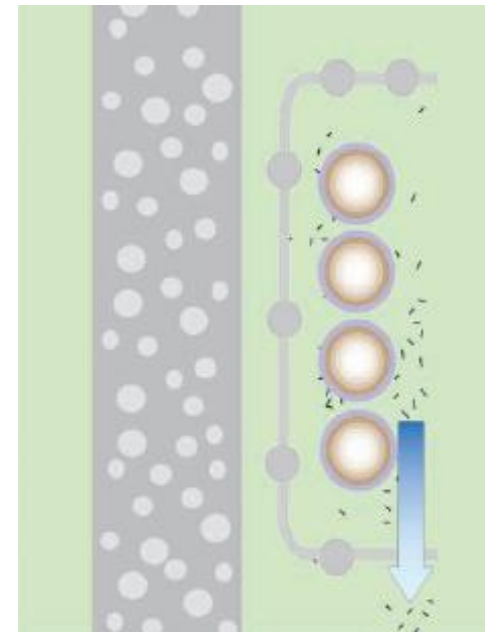



Easy to clean...

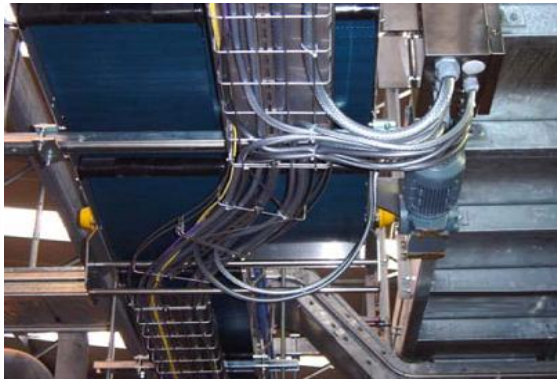

Around machines

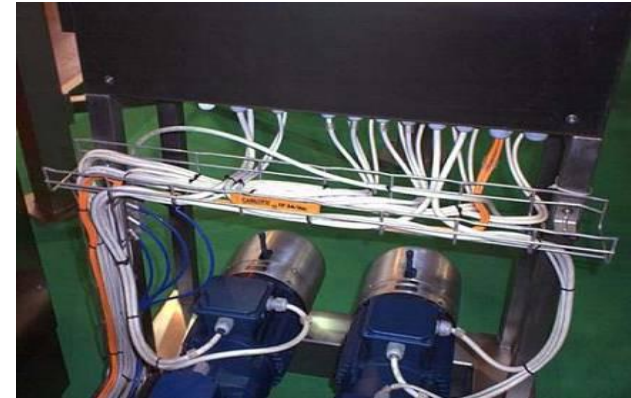

...inside & under machines



CABLOFIL® Wire Mesh Cable Tray



- Easy installation and multi-use cable trays



EZ

GC

EZ

GC

EZ

GC

304L

316L

304L

316L

304L

316L

50 to 300 mm

50 to 600 mm

100 to 600 mm

CF 30

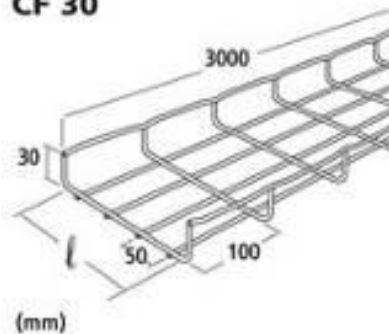

CF 54

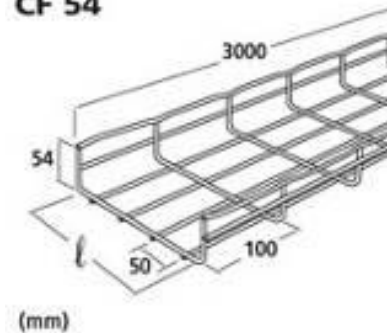

CF 105

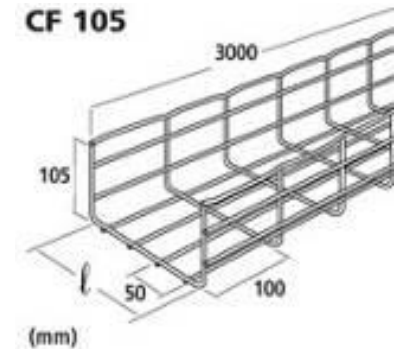

CABLOFIL® Wire Mesh Cable Tray



SPECIFICATION:

CABLOFIL is being manufactured with minimum diameters of:

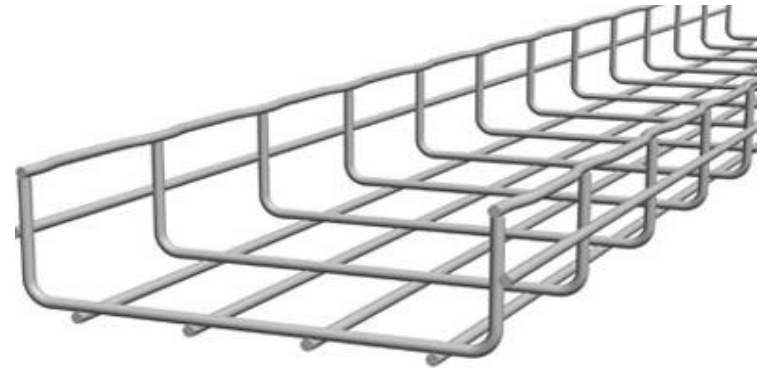

- **4 mm for trays of widths up to 100mm.....**
- **4.5 mm for trays of widths of 150mm, 200mm and 300mm.**
- **6.0 mm for trays of widths of 400mm, 450mm, 500mm and 600mm.**



CABLOFIL Fast splicing assembly system

EDRN Splice

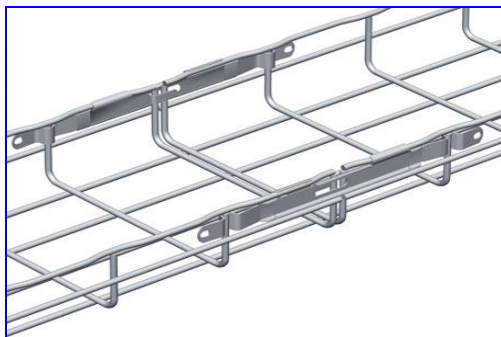

AUTOCLIC Splice

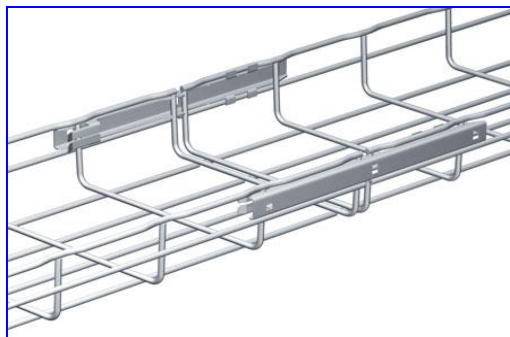

Good Bye Bolts & Nuts!

Forget the classical way to splice 2 together. EDRN & Autoclic splices allow a fast assembly and ensure the mechanical safety of the whole path

Dedicated solution for curves

FAS LOCK

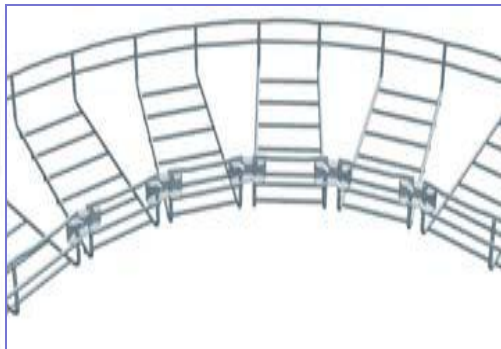

FAS CLICK

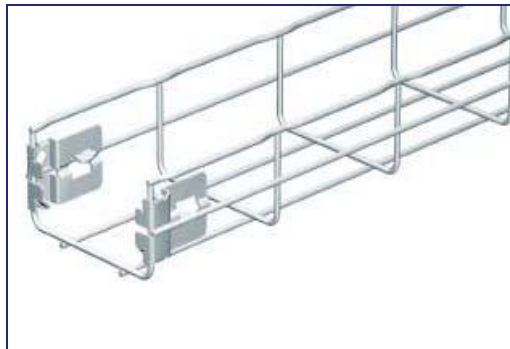

Electrical continuity

The electrical safety is a must. Our splices guarantees the safety of people and property by avoiding any risk of electrocution.

All our splices are tested!



Fast wall mounting

FAS 
FAST ASSEMBLING SYSTEM

CSN BRACKET

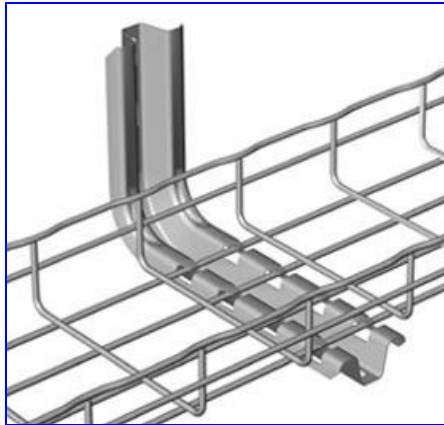

CU BRACKET WITH EDF

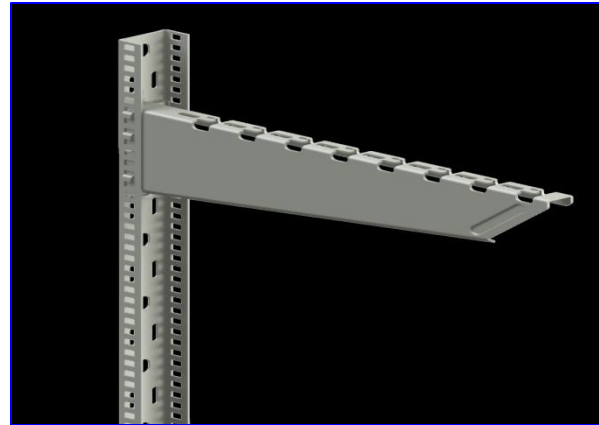

CM 50XL

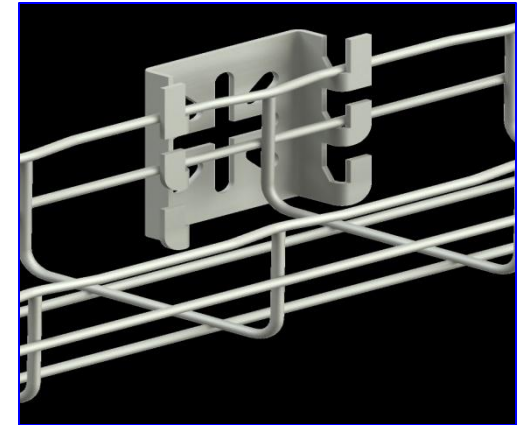

To the Wall, Horizontally



To the Wall, Vertically

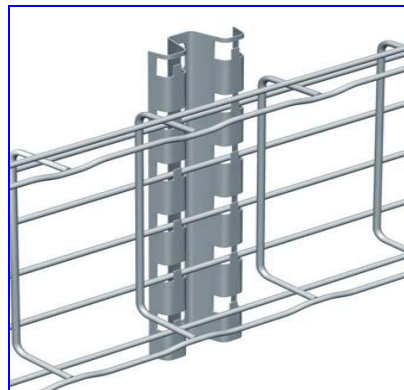

A complete range



From 30 to 105 mm



From 50 to 600 mm

Good Bye Bolts & Nuts!



Ceiling Mountings

CM50XL with TE6/CE40/EEC6

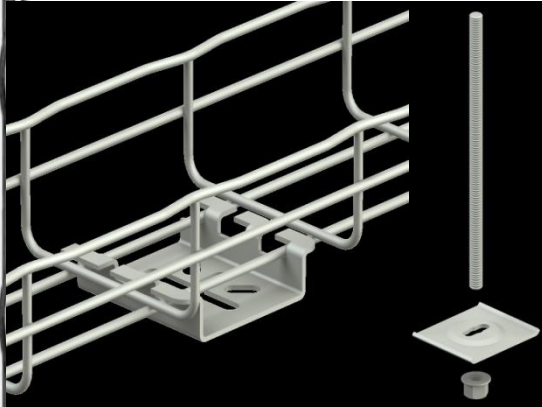

RCSN



SCF with PFSCF and EXT-SCF



AS with PA23

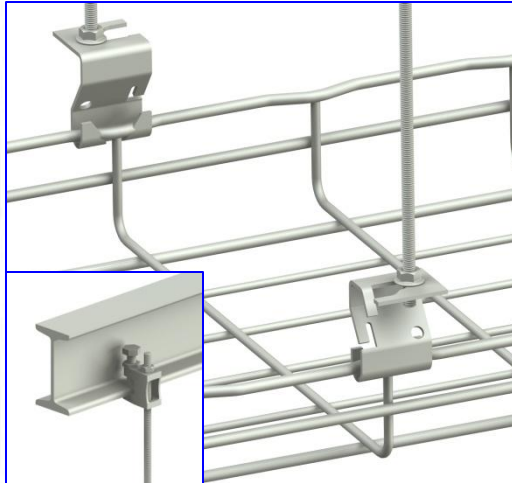

R41 Range Profiles, Rails & Brackets

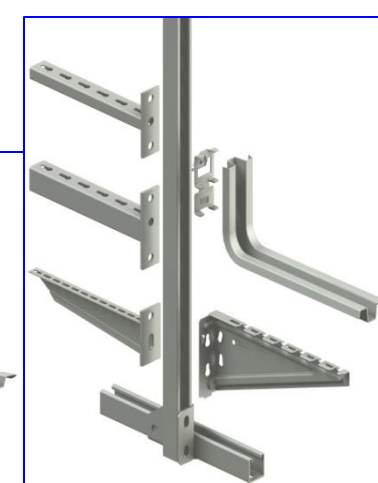
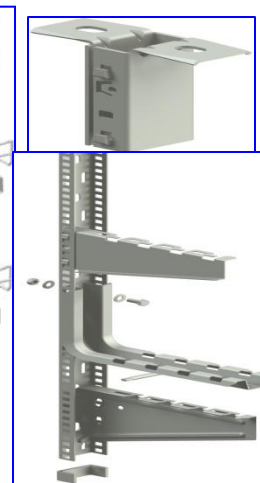
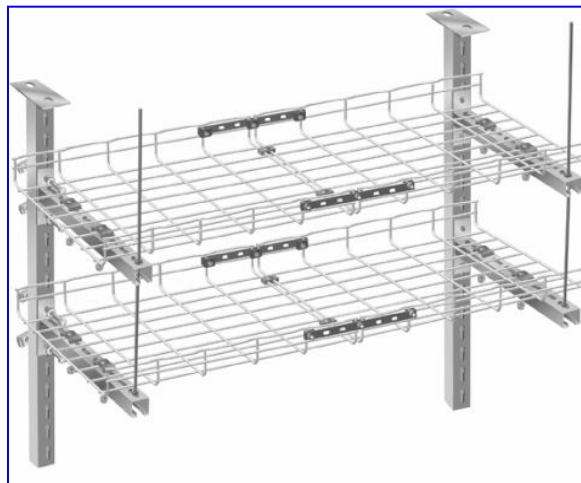

Floor Mountings

CSN with UFC Mounting

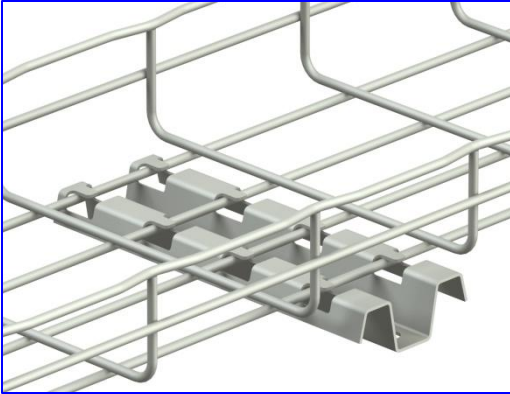

CSN with UFC Mounting

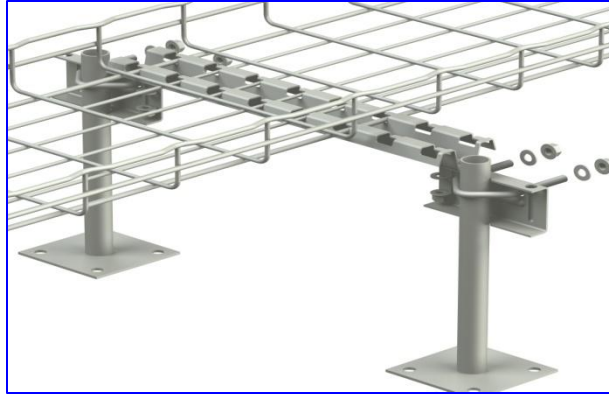

RCSN

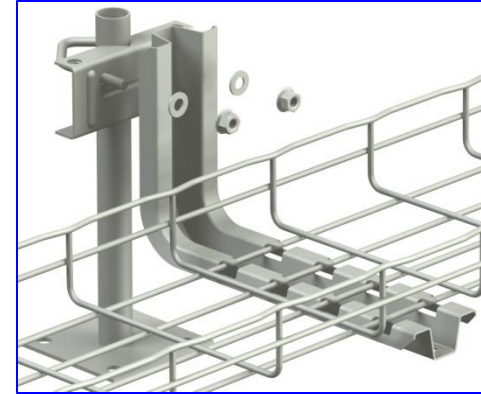

CM50XL

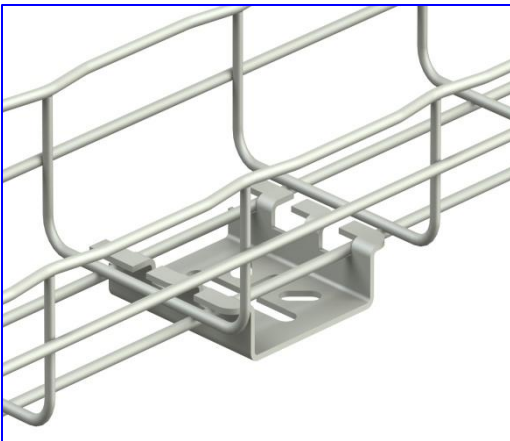

R55

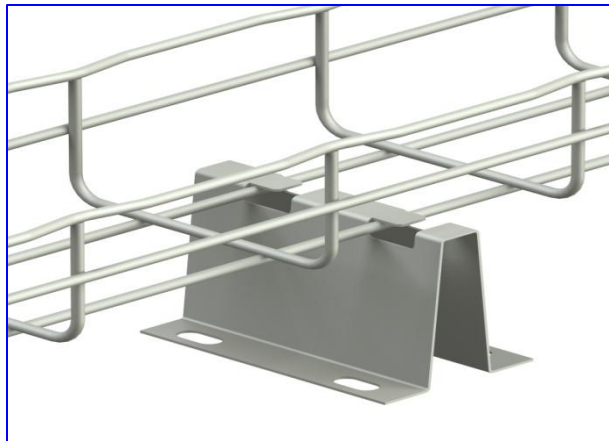

FTX

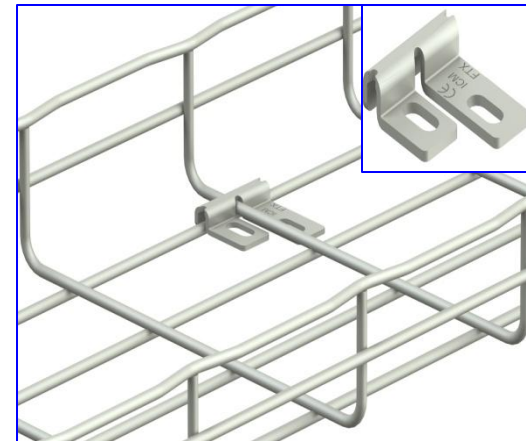

Cablofil® accessories

GRIFEQUIP

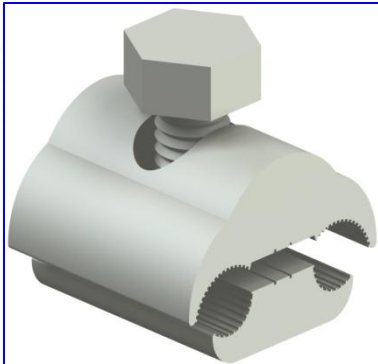

BTRCC/CE30/CE25

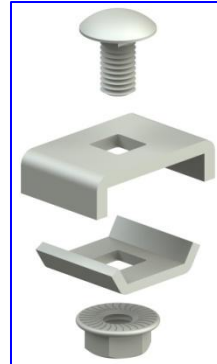

Separator

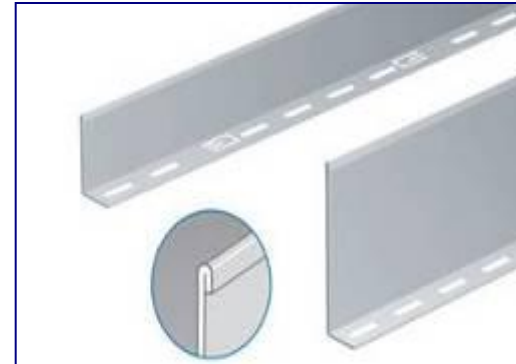

Cover

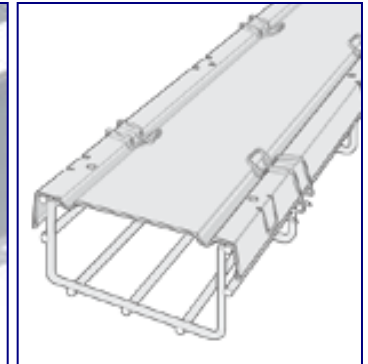

ED 275

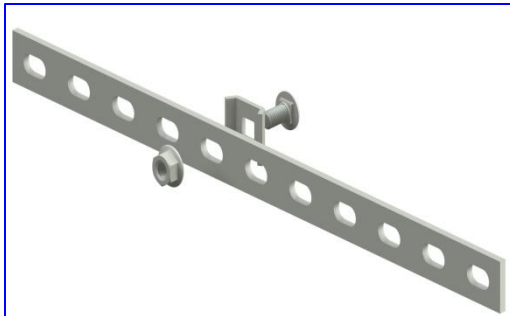

T with ED

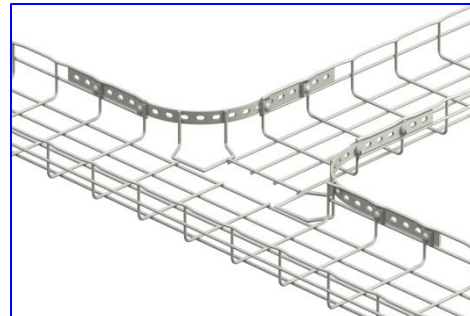

ED250/90

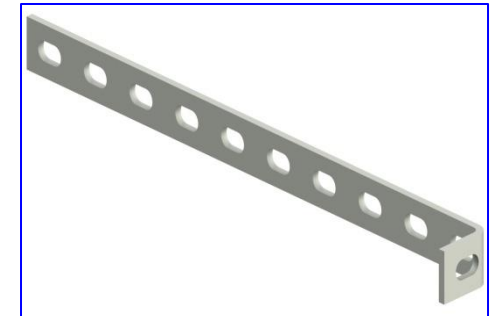

CABLOFIL® vs. Perforated Tray

Concern	Wire Mesh Cable Tray	Perforated Tray
Flexibility	On site made, bends /cross / T's = just cut with the bolt cutter. Bending Radius can be designed as per cable bending Radius	Lots of references to command. No adaptability.
Control	Open structure: easy control of the cables from all sides	Closed structure. Difficult to control
Cleanliness	Open structure: no dust retention, easy to clean	Dust retention
Price	Total cost of the installation is less	Total cost of the installation comes out to be more
Mounting	Easy mounting	Difficult mounting : lots of nuts and bolts
Time	Time saving solutions : nuts and bolts free solutions	Takes lot of time for installation
Maintenance	Fewer parts	Lots of parts and special orders

Concern	Wire Mesh Cable Tray	Perforated Tray
Repeated Accuracy / Alignment Issues	Its a Patented Design with no Such Problem	Alignment Problem and Repeat Accuracy issue are always there
Galvanization	Proper Galvanisation Process followed resulting in very long Life	Proper Galvanisation Process not followed resulting in peeling of Galvanisation layer after some time.
Earthing	Very Easy with Specific Accessories	Connecting Earthing Strip is a Problem
Burr on Tray Surface	Smooth Surface	De burring not done Properly after galvanisation resulting in cable damage
Mounting Supports	Light and Modular	Very Heavy and Difficult to mount
Ventilation / Cooling	Best in Class resulting in more amplicity for cables	Cable ventilation is a problem, resulting in use of higher cross sectional cables
Side Loading	Easy Patented T Edge	Sharp Edges resulting in cable Damage

CABLOFIL, the most worldwide tested tray



Fire rating
Mechanical Resistance
Earthing – Electrical Continuity
EMC
Corrosion
Vibrations tests
offshore & shipping agreements



Cablofil – Some Installations



For Ceiling Mountings

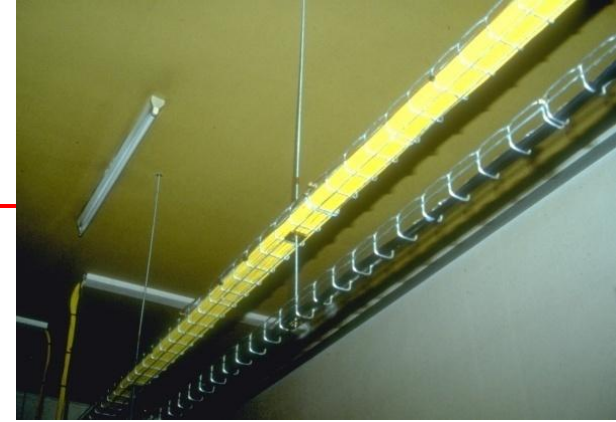

For under floor
mountings



For Wall
Mountings



LEGRAND India training

To hold lights

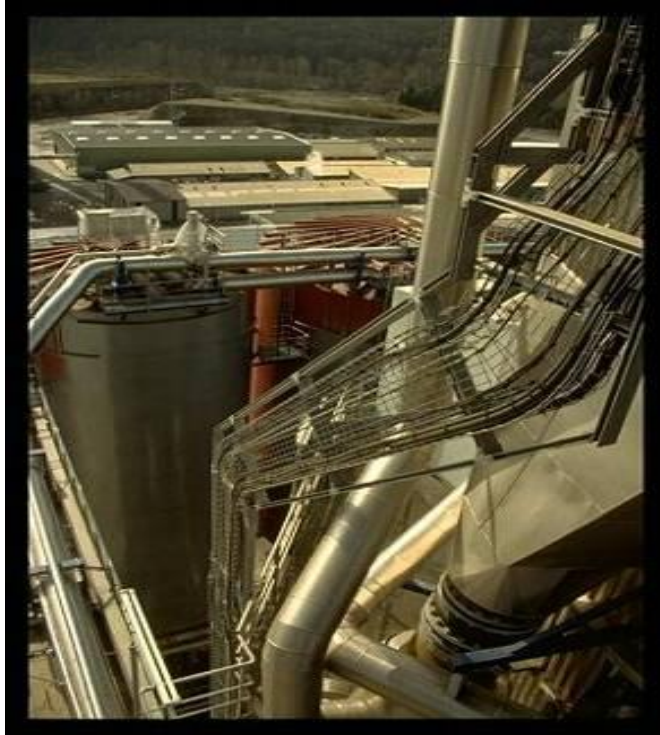

For vertical installations



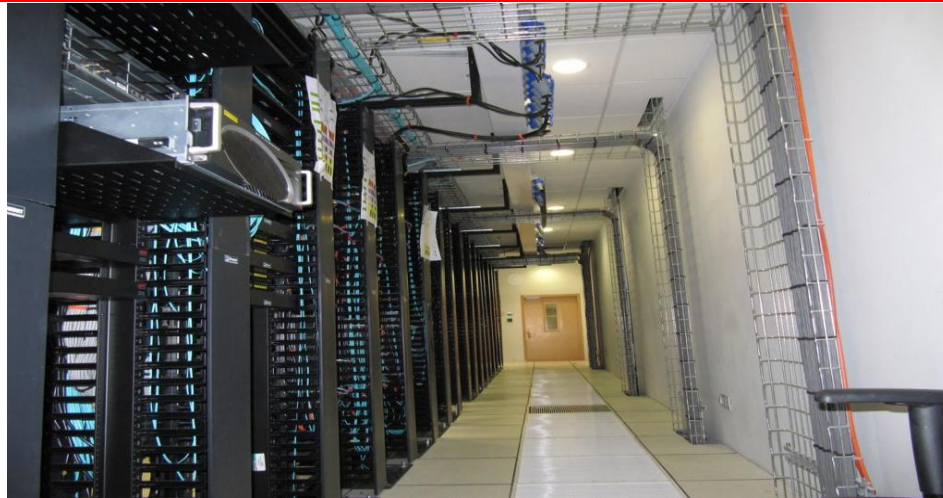

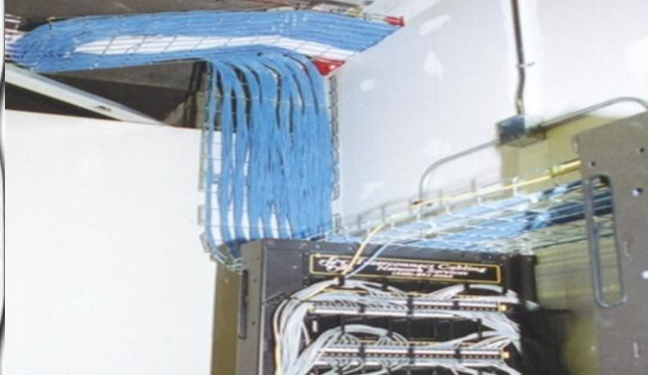

Directly on racks



Or on your desk

For a DATA / Power cabling combination

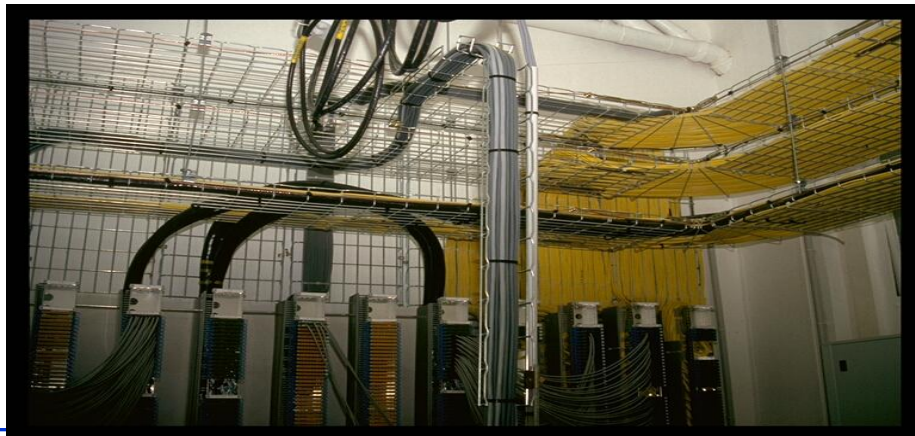

corrosive environments



sea, And offshore platforms



References: CABLOFIL® users



Mercedes-Benz



References:

1. Net magic Solutions
2. TCS (Powai)
3. Ferrero Group.
4. Barclays Bank.
5. Abbott Hotel.
6. Mumbai Airport.
7. Mumbai CST station.
8. CPWD.
9. Dynamix Dairy.
- 10.HDFC Data centre.